

Double-Acting Hollow Cylinders - DHC series

Doc. : L1037A Date : 2018/12

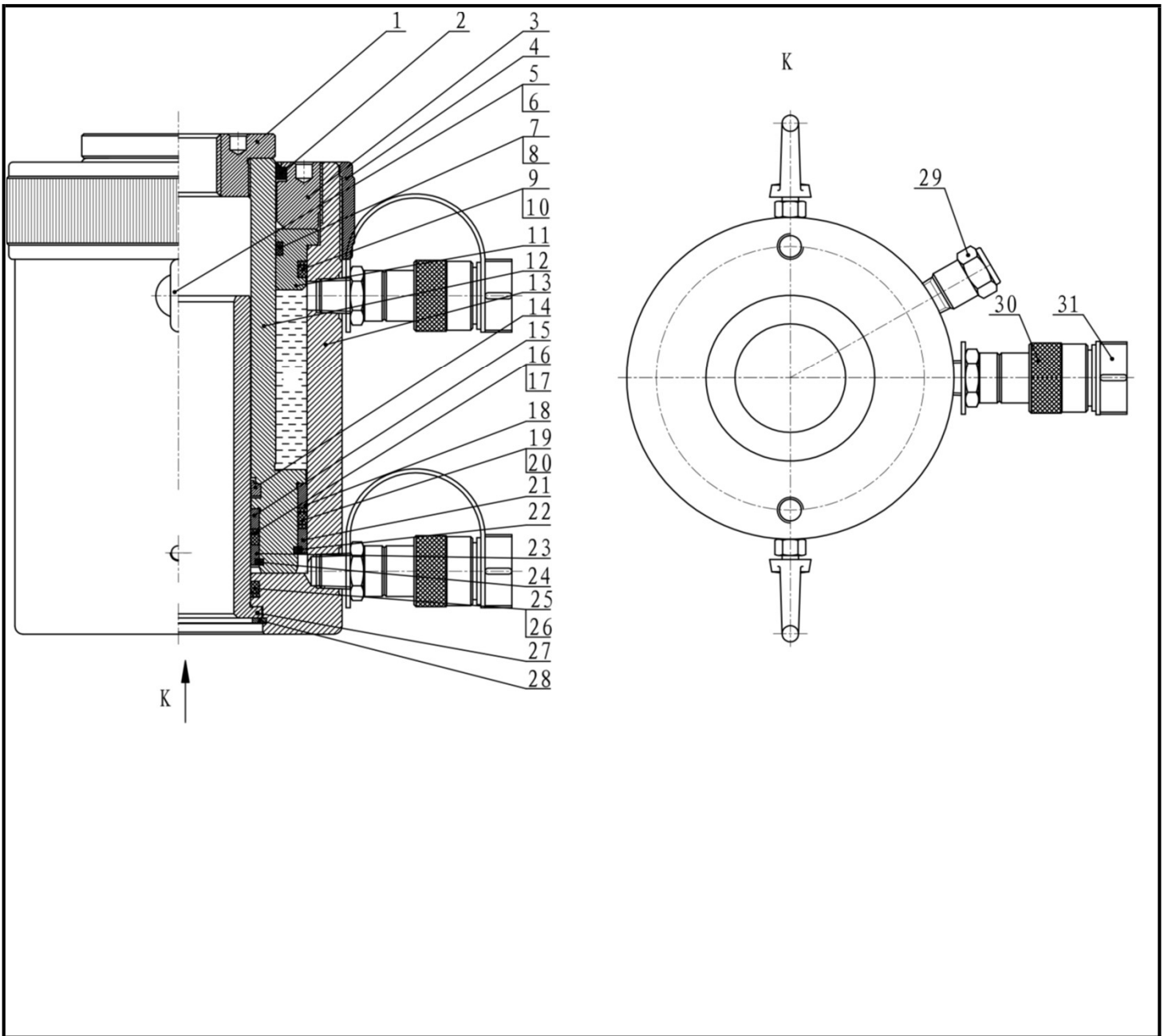

Item NO.	Description	Qty	Part NO.
			DHC 1000-38
1	Lifting head	1	2.001.02143
2	J-dustband	1	1.3.001.00033
3	Guide cap	1	2.001.03284
4	/	/	/
5	Lifting bolt (Item #6 included)	2	1.3.009.00005
6	Hexagon nut	2	-
7	Backup Washer	1	●
8	O- ring	1	●
9	Backup Washer	1	●
10	O- ring	1	●
11	/	/	/
12	Piston rod	1	2.001.03286
13	Oil cylinder	1	2.001.03285
14	J-dustband	1	1.3.001.00002
15	/	/	/
16	Backup Washer	1	●
17	O- ring	1	●
18	/	/	/
19	Backup Washer	2	●
20	O- ring	1	●
21	/	/	/
22	/	/	/
23	/	/	/
24	/	/	/
25	Backup Washer	1	●
26	O- ring	1	●
27	Centre hole	1	2.001.03287
28	Circlips for holes	1	1.3.017.00016
29	Safety valve	1	●
30	Female connector	2	1.3.025.00004
31	Connector protective jacket for NPT3/8"	2	1.3.097.00002
●	Repair kit	1	DHC 1000-38-RK