

# QD20 & 30 SWIVEL ASSEMBLY

REVISIONS				
ZONE	REV.	DESCRIPTION	DATE	APPROVED

## LOW PRESSURE (FEMALE- END)

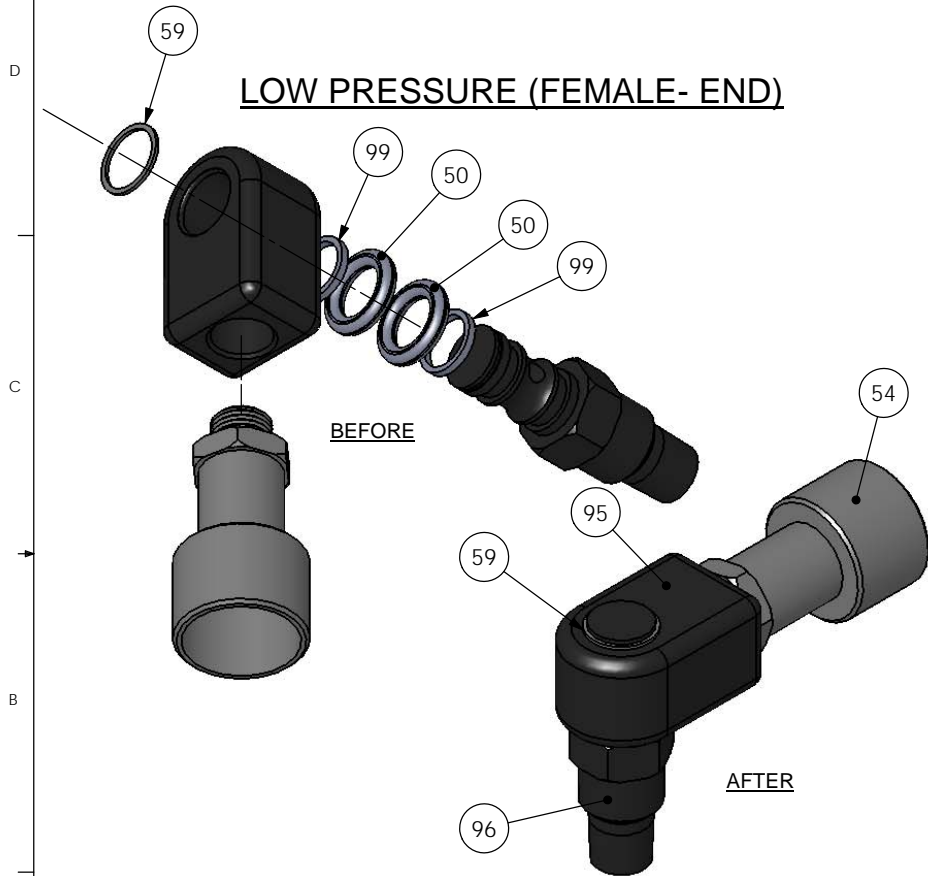

## HIGH PRESSURE (MALE- END)

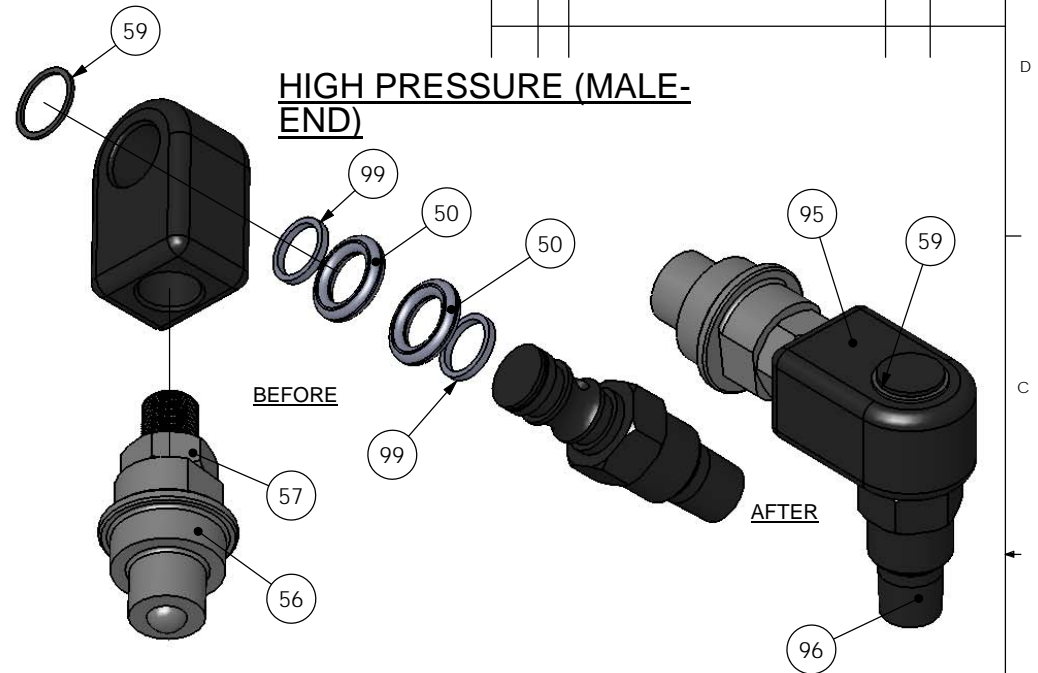

### ASSEMBLY INSTRUCTIONS

1. THREAD MALE QUICK CONNECT (ITEM 56) INTO NIPPLE (ITEM 57).
2. THREAD ASSEMBLED ITEMS (56 & 57) INTO SWIVEL (95).
3. PLACE THE MODULAR SEAL BACKUPS (ITEM 99) AND THE SEALS (ITEM 50) ONTO THE POST IN THE ORDER SHOWN.
4. WHEN PLACING THE MODULAR SEAL BACKUPS (ITEM 99) MAKE SURE THE CONCAVE SIDE OF THE SEAL IS FACING TOWARD THE MATING SEAL.

SOFTWARE: SOLID WORKS	DATE	NAME	<b>BOLTTECH</b> We Own the Future of Bolting Technology	
UNLESS OTHERWISE SPECIFIED: DIMENSIONS ARE IN INCHES FRACTIONAL +/- 1/32" ANGULAR +/- 1/2 DEGREE TWO PLACE DECIMAL +/- 0.01 THREE PLACE DECIMAL +/- 0.005	DRAWN		CUSTOMER:	
	CHECKED		TITLE:	
	ENG APPR.		SIZE <b>B</b> DWG. NO.	
	MFG APPR.		REV	
MATERIAL			SCALE: 1:2 WEIGHT: SHEET 8 OF 17	
HEAT TREAT	PROPRIETARY AND CONFIDENTIAL THE INFORMATION CONTAINED IN THIS DRAWING IS THE SOLE PROPERTY OF BOLTTECH. ANY REPRODUCTION IN PART OR AS A WHOLE WITHOUT THE WRITTEN PERMISSION OF BOLTTECH IS PROHIBITED.			
FINISH				